

PDL Meter

PL2000

In fiber optic communication systems, Polarization Dependent Losses of components can increase signal distortion and result in performance degradation. Therefore, for the fiber optic component manufacturers, an accurate and efficient PDL measurement is very important.

FIBERPRO's PDL Meter, PL2000, measures Polarization Dependent Loss (PDL) and Insertion Loss (IL) of optical components simultaneously as a function of wavelength (wavelength-swept measurement). In addition, optical power measurement function is provided.

FIBERPRO's powerful PDL measurement method - fast "Polarization scanning" (TIA/EIA-455-157) - enables PL2000 to achieve very high accuracy with the world's fastest measurement speed (0.1 sec. typ.)

The PL2000 is an ideal solution for measuring PDL and IL of DWDM components efficiently and accurately.

PDL



Features

- Fast Measurement Speed
- Polarization Scanning Method (All-States method)
- All fiber technology
- Acquires PDL and IL measurements simultaneously
- Optical power meter function
- No calibration needed
- GPIB and RS232 remote interface



PDL Meter

Applications

1. Fast and precise measurement of PDL (Polarization Dependent Loss) and IL (Insertion Loss) of fiber optic components

For most of DWDM components, it is required to characterize PDL and IL as a function of wavelength. Based on FIBERPRO's unique all-fiber technologies, the PL2000 can simultaneously measure PDL and IL of fiber optic components in a very short time, typically 0.1 seconds for one measurement. This measurement speed is ten to hundred times faster than conventional methods.

Moreover, PL2000 has no wavelength dependence on PDL measurement and needs no calibration process since it is based on Polarization scanning method (All-States method) (TIA/EIA-455-157). Due to its excellent speed and accuracy, PL2000 is especially suitable for automatic measurement of wavelength dependence of PDL and IL of DWDM components. With tunable lasers, optical switches, and remote control programming, the user can set up various measurement schemes. The following figures show some examples.

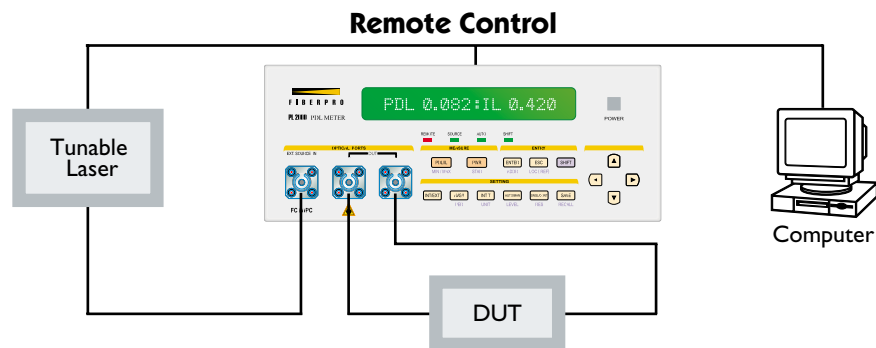

[Figure 1] Scheme for measurement of PDL and IL as a function of wavelength

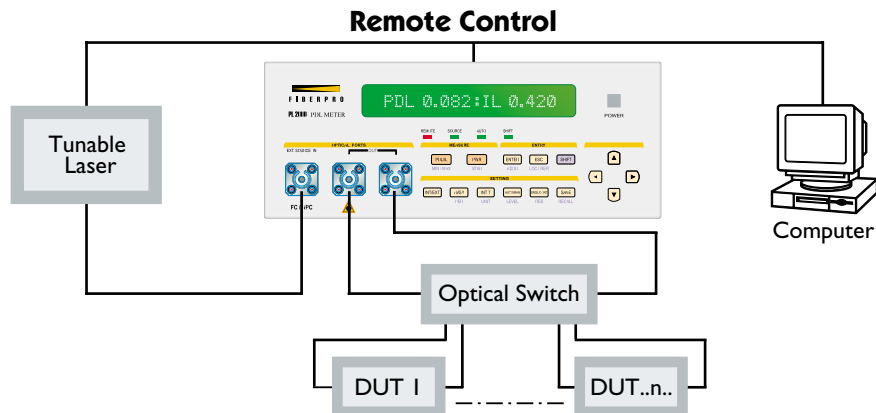

[Figure 2] Scheme for measurement of PDL and IL as a multiple DUTs

2. Measuring of the Highest PDL result

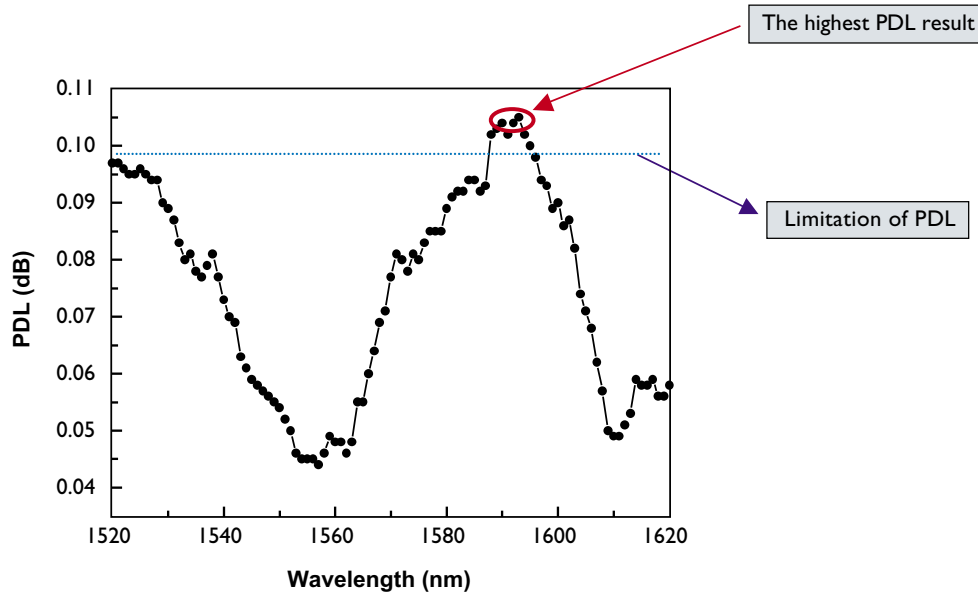

[Figure 3] Measurement data of the Highest PDL result

PL2000 satisfies the special requirements of component manufacturers who want to get a fast evaluation when a component has higher PDL levels than their expected specification for the whole wavelength range.

When a customer wants to know whether the highest PDL result can meet adaptable PDL value specification, PL2000 defines this at very fast measurement speed.

3. Optical power meter function

PL2000 also provides an optical power meter function.

The user can measure optical power of external laser sources.

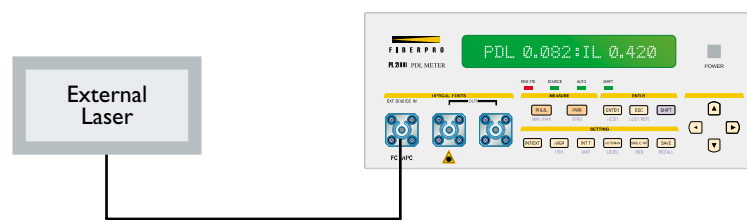

[Figure 4] Scheme for measurement of PDL and IL as a function of wavelength

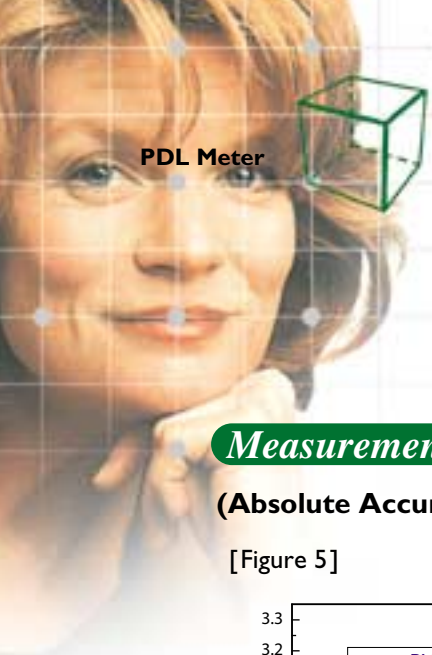

PDL Meter

Measurement Data

(Absolute Accuracy)

[Figure 5]

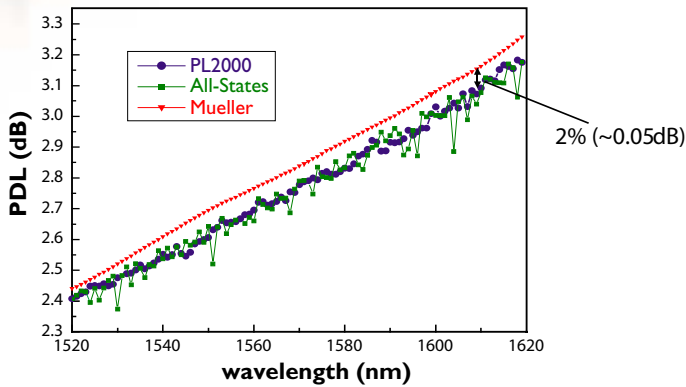

In this PL2000 measurement data figure (5), 'Artificial PDL sample #2 (0.70 dB @1555 nm)' is used as a DUT (Device under Test).

[Figure 6]

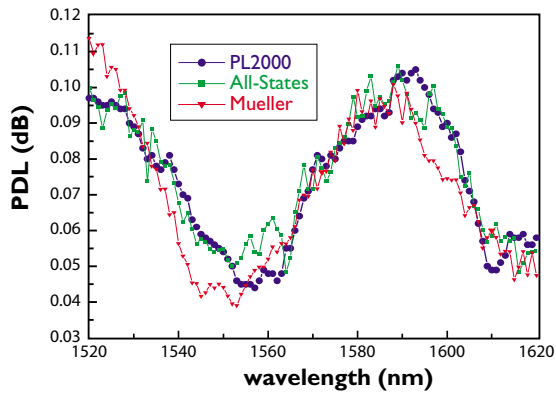

In this PL2000 measurement data figure (6), 'Isolator (~0.1 dB)' is used as a DUT

[Figure 7] Measurement Result - Input Polarization Dependency

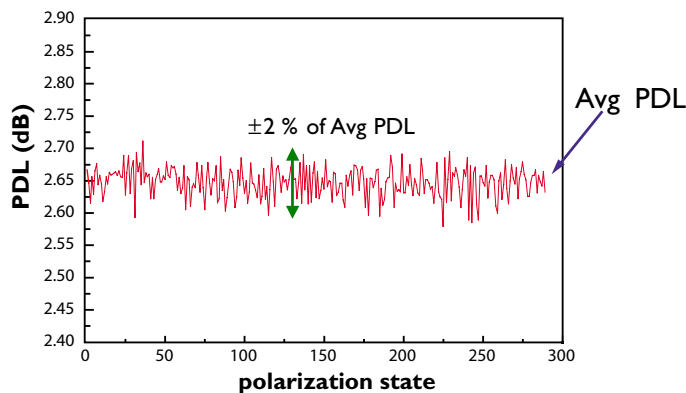

In this figure (7), the graph shows an experimental scheme and the result. All of the PDL results are in agreement within $\pm 2\%$ of average PDL. This means PL2000 is almost independent on input polarization and covers Poincare sphere fully and uniformly.

Specification

Operating Wavelength Range	
PDL	1310 ~ 1620 nm
IL	1310 nm, 1520 ~ 1620 nm
Resolution	0.1 dB, 0.01 dB, 0.001 dB
PDL/IL Measurements	
PDL Accuracy	$\leq \pm(0.010 + 5\% \text{ of PDL})$ dB maximum $\leq \pm(0.010 + 2\% \text{ of PDL})$ dB typical
IL Accuracy	$\leq \pm(0.1 + 2\% \text{ of IL})$ dB maximum
PDL / IL Measurement speed	0.1 sec. Typ.
PDL Range	0 to 5 dB
IL Range	50 dB
Power measurements	
Power Accuracy ¹⁾	± 0.2 dB @ -10 dBm
Power Range	+3 dBm to -57 dBm
Operating Temperature	10°C ~ 40°C
Storage Temperature	0°C ~ 60°C
Dimensions (W × H × D)	225 × 88 × 420 mm

¹⁾ The average optical power after DUT must be greater than -22 dBm.
(corresponding to 20 dB of IL when the input optical power is maximally launched)

*APC type connector only at External source input adaptor

The specifications and technical information contained herein are subject to change without notice and are furnished without charge or obligation. They are given and accepted at recipients sole risks.

Ordering Code

PL2000-(1)-(2)

1. internal source → include (S), not include (X)
2. connector type → FC/SPC (F/P), FC/APC (F/A)

Example : PL2000-S-F/A

→ PDL Meter with FC/APC connectors. (internal source include)